

TELESCOPIC CONVEYOR

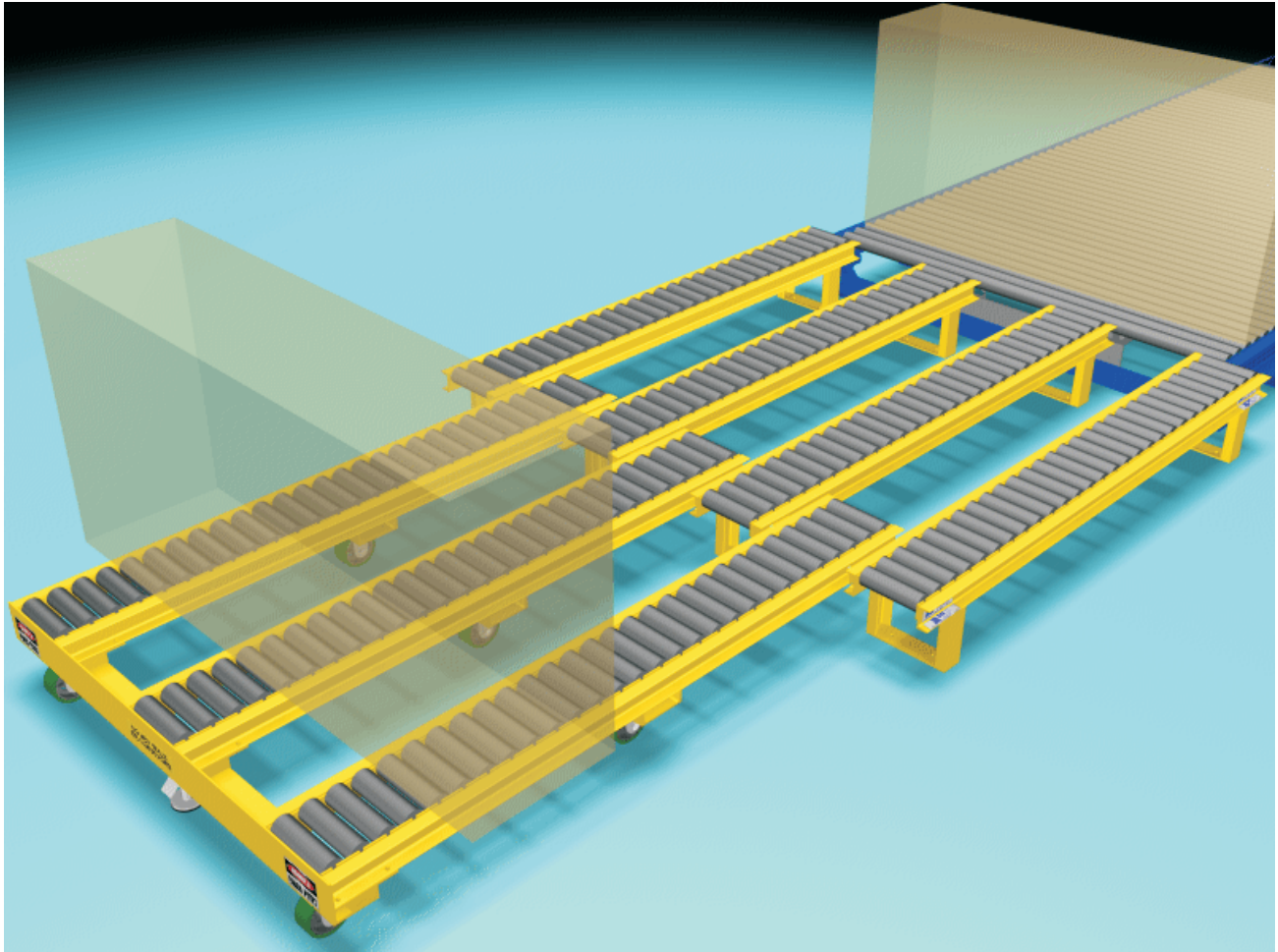

SERVICE AND MAINTENANCE MANUAL

TABLE OF CONTENTS

DESCRIPTION	PAGE NO.
Telescopic Conveyor (TEL)	2
Conveyor Safety	3
TEL Service and Parts	4
Parts Information	6
Maintenance Schedule	7

LIST OF ILLUSTRATIONS	PAGE NO.
A Telescopic Conveyor	2
B Telescopic Conveyor Fully Opened	2
C Safety Label Locations	3

LIST OF ASSEMBLY DRAWINGS	PAGE NO.
1 TEL Load Carrying Rollers	4
2 TEL Caster Assembly	5
3 TEL Delrin Wheel Assembly	5

When ordering parts, please call, fax or e-mail Systec at the address and/or the numbers shown below.

SYSTEC Conveyors Parts Department
10010 Conveyor Drive
Indianapolis, IN 46235

Tel 317.890.9230
1.800.578.1755
Fax 317.890.9232

On The Net @ <http://www.systecconveyors.com/>
e-mail: info@systecconveyors.com

TELESCOPIC CONVEYOR

The information within this manual covers **SYSTEC's** standard Roller Transfer Device. From this point on, the device will be referred to as a TEL.

SYSTEC's TEL is designed for use at a converting machine infeed that requires "roll-out" of the feed section. The TEL's easy collapsability creates the space necessary for the converting machine to roll-out for maintenance or change out of print section, plates, etc.. The TEL also allows the operator to pull the mobile conveyor feed section to the desired length for delivery of a stack of sheets.

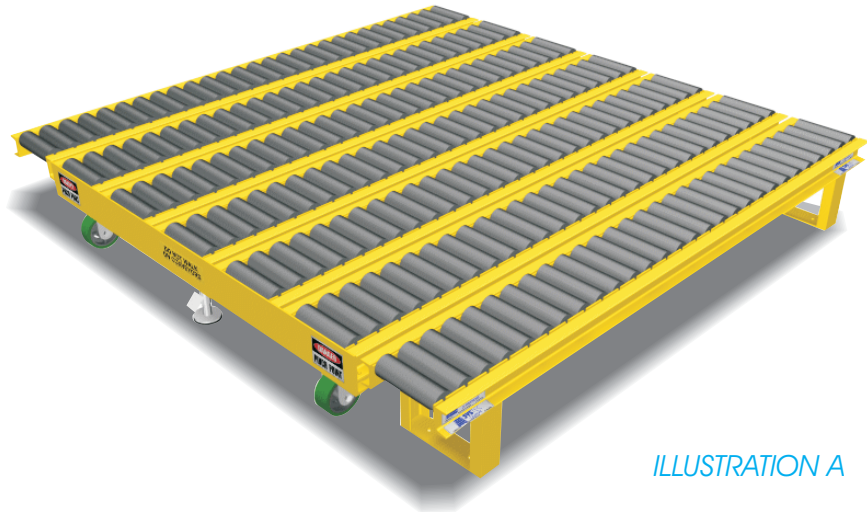

ILLUSTRATION A

TELESCOPIC
CONVEYOR

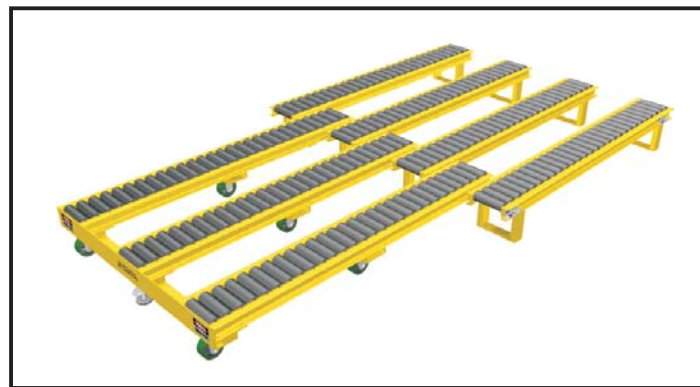

ILLUSTRATION B

TELESCOPIC
CONVEYOR
FULLY
OPENED

TELESCOPIC CONVEYOR SAFETY

Where safety is concerned, conveyor and its devices are no different from any machinery or processing equipment. In many cases, the conveyor and devices can start running without notice.

SYSTEC designs all its equipment to be as safe as possible by installing guarding, or providing safety labels on all conveyor and devices. These labels are in place to warn personnel working on or around the conveyor system of the inherent dangers that exist with any conveyor or machinery.

SYSTEC Conveyors also believes that a conveyor safety session should be incorporated into your existing safety training program to educate all personnel that work on or around conveyor systems of these potential safety concerns.

Below is Illustration B, showing the safety labels provided with **SYSTEC's** TEL. These labels should be installed to alert personnel of the potential hazards caused by improper use of the conveyor equipment. Where foot traffic exists, personnel should be discouraged from walking on a conveyor line.

Should you need additional labels, please contact **SYSTEC's** Parts Department at the address or phone numbers shown in the front of this manual.

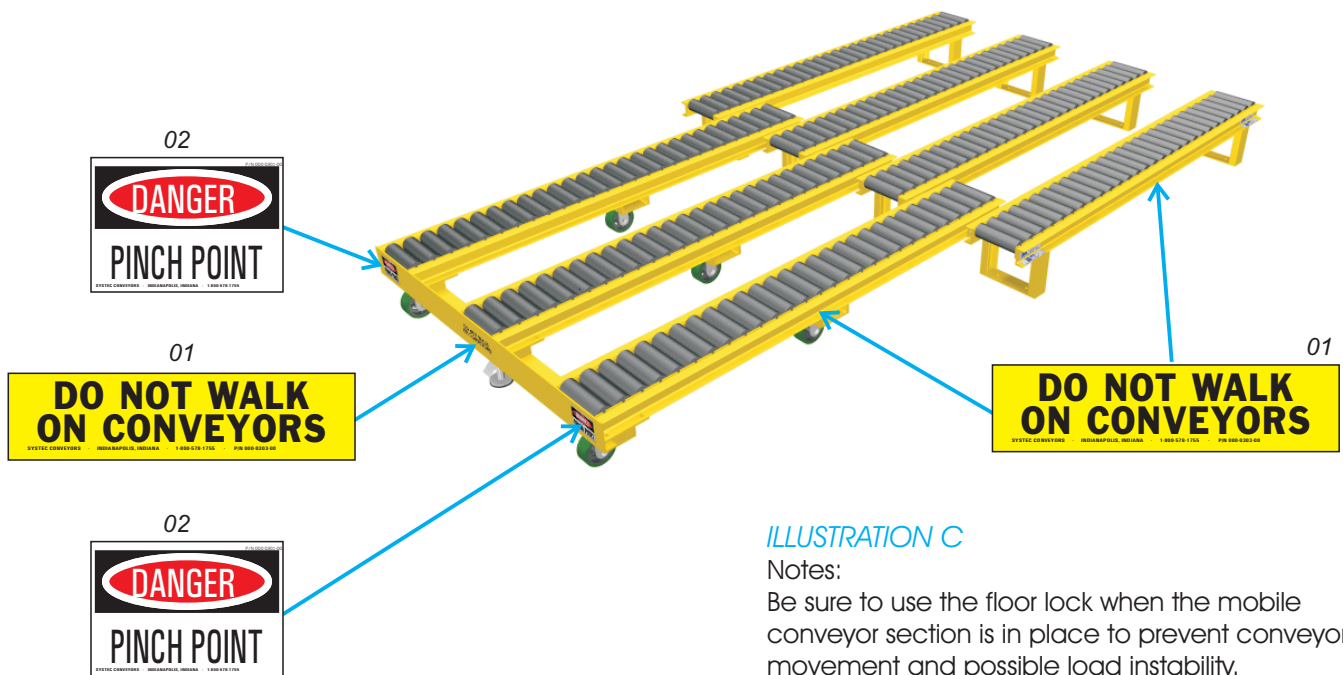

Note: Only authorized personnel should perform service and maintenance on any conveyor equipment and controls.

TELESCOPIC CONVEYOR SERVICE AND PARTS

The drawings within this section are designed to help you understand how components of the TEL are assembled and disassembled. The exploded views also allow you to quickly and easily identify the parts that may need to be serviced and/or repaired.

The parts identification page(s) provide the corresponding part numbers to the drawings, and indicates recommended quantities you should stock for each TEL, along with the parts descriptions, part numbers, and order quantities. This is a faxable form, for your convenience, to order parts for stock or needed replacement parts. Simply fill in the order quantity, the necessary purchase order number, and shipping information, then fax the form to **SYSTEC** Conveyor's at the number shown on the form. An Order Acknowledgement will be faxed back with the estimated ship date and pricing information.

The drawing below shows the TEL and the load carrying rollers in the associated conveyor. When ordering, be sure to specify the exact size of rollers needed and identify for **SYSTEC's** Parts Department the device type for which the rollers are needed.

LOAD CARRYING ROLLERS

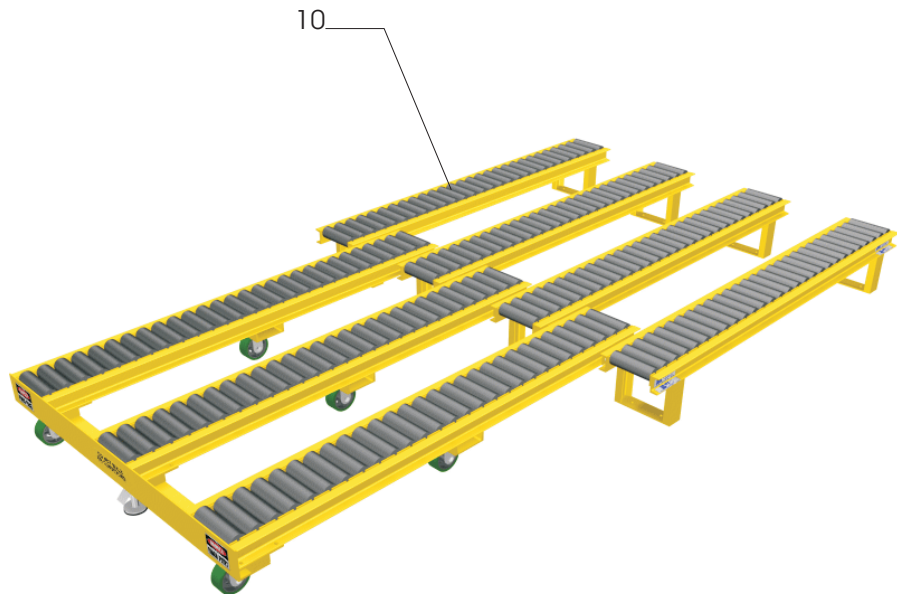

ASSEMBLY DRAWING 1

Notes:

Rollers within all sections of the TEL are the same size.

TELESCOPIC CONVEYOR SERVICE AND PARTS (continued)

ASSEMBLY DRAWING 2

Notes:
Use only rigid mount, fixed direction caster. Swivel casters will not work for this device.

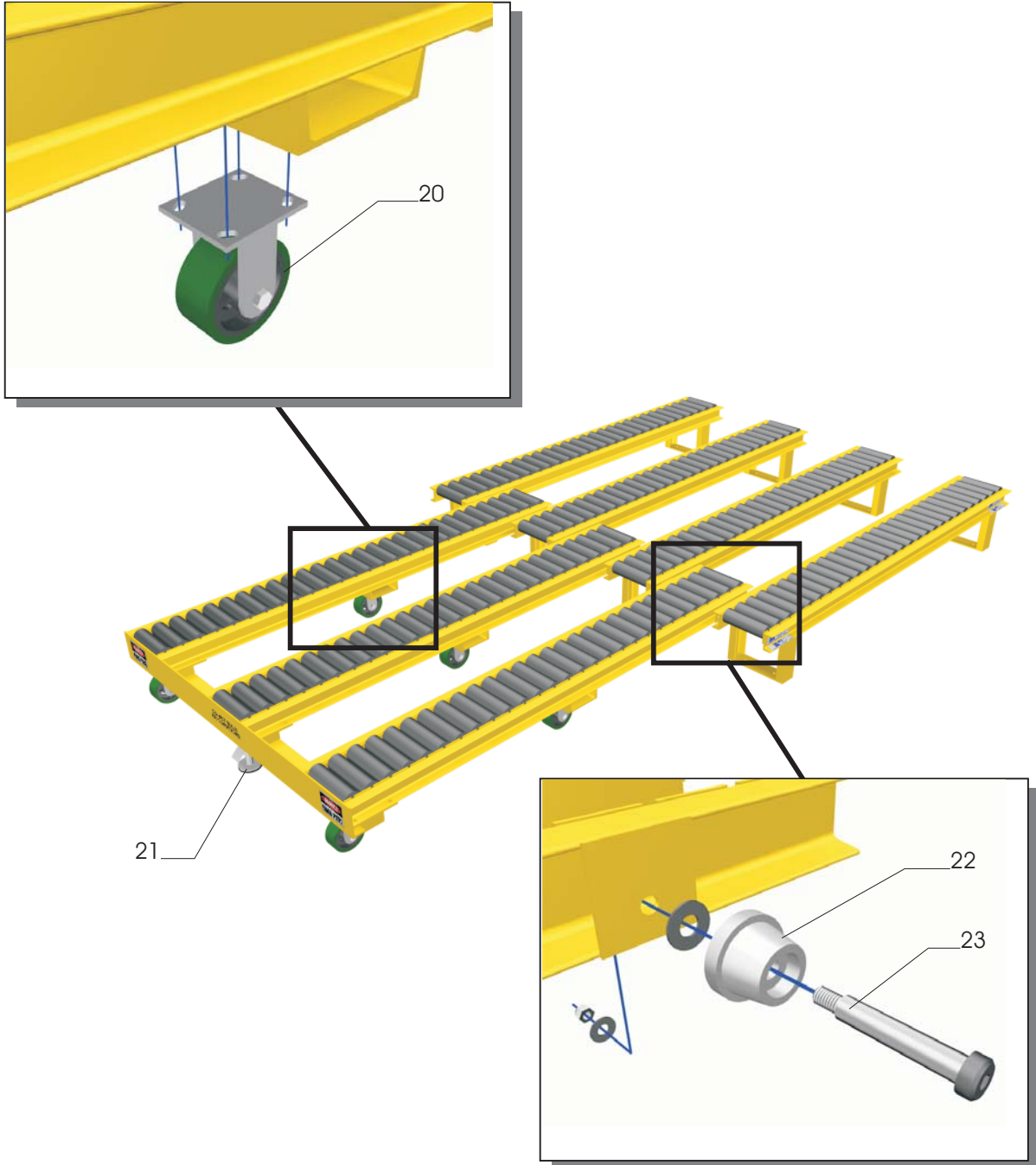

ASSEMBLY DRAWING 3

Notes:
Lubrication is not required for the Delrin (white) wheels..

Some items on this parts list require "fill-in" or additional information to receive the needed part. Please be sure to provide all information requested on this list, or within this manual to assure that you do infact get exact replacement parts. Systec's Parts Department will assist you in obtaining the proper part information, or answering any questions by calling 1-800-578-1755.

Item	Qty.	Rec. Spare	Description	Part Number	Gr.	Order Qty.
1	5		Safety Label - Do Not Walk On Conveyor	000-0303	-00	
2	2		Safety Label - Pinch Point	000-0301	-00	
10	*		8-1/4" Roller, 7/16" HEX, 14ga, L.O.	10D0001	19	
20	5	1	Caster, 5" Dia., 2" Face, 6-1/2" OAH	985-0100	-00	
21	1		Floor Lock	985-9500	-00	
22	6	2	Telescoping Conveyor Guide Wheel	34B0010	00	
23	6	2	Bolt, Shoulder, 1/2" X 2-1/2" L.	835-1025	-00	

* Please specify Quantity and/or Length for any bill-of-material items with an asterisks.

For gearmotor information refer to Page 6, as indicated in this material list, to identify the motor and gearbox data plate information needed to order exact replacement parts.

This Maintenance Schedule is intended to cover all basic types of conveyor and the related devices and components. Although your system may not have all the parts listed below this schedule should help in identifying those components or parts that may require service or inspection that may otherwise be neglected. Should you need assistance in identifying the location of some of these components, contact **SYSTEC's** Customer Service Department at **1-800-578-1755**.

ITEM	INSPECTION OR SERVICE REQUIRED	HOURS IN SERVICE				
		500	1,000	2,500	5,000	10,000
Gearmotor	Clean, Check for Noise, Leaks, and Mounting	X				
	Check Oil Level			X		
	Change Oil					X
Bearings	Check Roller Bearings for Noise				X	
	Check Pillow Block (PB) and Flange Block (FB) bearings for Noise, Mounting, and *Lubrication	X				
Belt	Check for Belt Wear, Tracking and Tension		X			
Chains	Check Tension, Wear, Lube and Adjustment	X				
Wire Cables	Check Tension, Wear, and Adjustment	X				
Springs	Check Tension, Wear, and Adjustment	X				
Sprockets	Check Alignment, Wear and Mounting	X				
Pulleys	Check Alignment, Wear and Mounting	X				
UHMW Blocks and Pads	Check for Wear and Fit			X		
Cams and Rollers	Check for Wear and Alignment	X				
Transfer Rails	Clean with Degreaser	X				
Photoeyes	Clean with Soft Cloth or Dry High Pressure Air	X				
Limitswitches	Clean debris and Check Arm for Free Movement	X				
Proximity Switch	Clean Debris and Check for Proper Operation	X				
Pendant Switch	Check for Proper Operation			X		
Lockout Switch	Check for Proper Operation and Safety Labels			X		
Foot Switch	Check for Proper Operation			X		
Foot Valve	Check for Proper Operation			X		
Strobe Light	Check for Proper Operation			X		
Sound Alert	Check for Proper Operation			X		
Motion Detector	Check for Proper Operation			X		
Load Measuring Device	Check for Proper Operation			X		
Air Filter/Regulator	Check and Clean Trap and Adjust Pressure	X				
Solenoid Valve	Check for Air Leaks			X		
Air Mount (air bag)	Check for Air Leaks	X				
Air Supply Line	Check for Air Leaks	X				

* Check bearing type for regreasable (zerk) fitting. Some bearings may be "sealed-for-life" and do not require regreasing.

